

## STANDARD MODEL SPECIFICATIONS

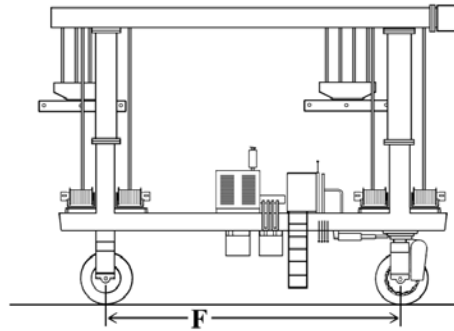
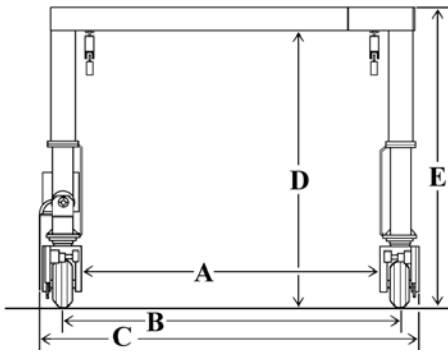

HOIST MODEL	E-MX-20/4	E-MX-30/4	E-MX-40/4
Maximum Capacity	40,000 LBS (18,144 KG)	60,000 LBS (27,216 KG)	80,000 LBS (36,287 KG)
A. Inside Clear Width	17' (5.18 m)	18' (5.48 m)	20' (6.09 m)
B. Tread Width (Tire Centers)	19' (5.79 m)	20'-2" (6.14 m)	22'-2" (6.75 m)
C. Overall Width	22' (6.70 m)	23'-6" (7.16 m)	26' (7.92 m)
D. Inside Clear Height	18' (5.48 m)	19' (5.79 m)	20' (6.09 m)
E. Overall Height	19'-8" (5.99 m)	20'-10" (6.34 m)	22' (6.70 m)
F. Wheelbase	16'-6" (5.02 m)	18' (5.48 m)	20' (6.09 m)
Inside Turning Radius	0"	0"	0"
Outside Turning Radius	26'-2" (7.97m)	28'-1" (8.55 m)	30'-11" (9.41 m)
Cable Drop below Grade	7' (2.13m)	7' (2.13 m)	7' (2.13 m)
Slings	(2) 10" x 26' (.25 m x 7.92 m)	(3) 10" x 30' (.25 m x 9.14 m)	(4) 12" x 34' (.30 m x 10.36 m)
Hoisting Speed	32' P.M. (9.75m)	23'-8" P.M. (7.21m)	19'-8" P.M. (5.99 m)
Travel Speed	163' P.M. (49.68 m)	170' P.M. (51.81 m)	75-132' P.M. (22.8-40.2 m)
Gradeability	6%	6%	6%
Tires, Recap Aircraft (30-ply)	44 x 16	46 x 16	49 x 17
Engine	John Deere Tier 3 Turbo Diesel	John Deere Tier 3 Turbo Diesel	John Deere Tier 3 Turbo Diesel

HOIST MODEL	E-MX-55/4T	E-MX-85/4T	E-MX-100/4T
Maximum Capacity	110,000 LBS (49,895 KG)	170,000 LBS (77,110 KG)	200,000 LBS (90,718 KG)
A. Inside Clear Width	21' (6.40 m)	24' (7.31 m)	26' (7.92 m)
B. Tread Width (Tire Centers)	23'-5" (7.13 m)	26'-8" (8.12 m)	28'-8" (8.73 m)
C. Overall Width	27' (8.22 m)	30' (9.14 m)	33' (10.05 m)
D. Inside Clear Height	21' (6.40 m)	24' (7.31 m)	28' (8.53 m)
E. Overall Height	24' (7.32 m)	27' (8.23 m)	32' (9.75 m)
F. Wheelbase	22' (6.70 m)	26' (7.92 m)	28' (8.53 m)
Inside Turning Radius	0"	0"	0"
Outside Turning Radius	33'-2" (9.19 m)	38'-4" (11.68 m)	41'-2" (12.54 m)
Cable Drop below Grade	7' (2.13m)	7' (2.13 m)	7' (2.13 m)
Slings	(4) 12" x 36' (.30 m x 10.97 m)	(4) 16" x 38' (.40 m x 11.58 m)	(6) 16" x 44' (.40 m x 13.41 m)
Hoisting Speed	17' P.M. (5.18 m)	13' P.M. (3.96 m)	13' P.M. (3.96 m)
Travel Speed	75-132' P.M. (22.8-40.2 m)	76-137' P.M. (23.16-41.75 m)	76-137' P.M. (23.16-41.75 m)
Gradeability	5%	4%	4%
Tires, Recap Aircraft (30-ply)	50 x 20 x 20	52 x 20.5 x 20	26.5 x 25 Radial
Engine	John Deere Tier 3 Turbo Diesel	John Deere Tier 3 Turbo Diesel	John Deere Tier 3 Turbo Diesel